S P E C I F I C A T I O N
L i t h i u m B a t t e r y
CR1620

MATSUSHITA BATTERY INDUSTRIAL CO., LTD.

LITHIUM & MICRO BATTERY DIVISION



S P E C I F I C A T I O N

Lithium Battery CR1620 (Li/MnO₂)

1. Model No. : CR1620
2. Nominal Voltage : 3 V
3. Nominal Capacity : 75mAh
4. Nominal Weight : 1.3 g
5. Dimension : Shown in Figure
6. Terminal : ⊕ Case , ⊖ CaP
7. Characteristics :
 - 1) Off-Load Voltage : Shown in Table
 - 2) Internal Resistance: Shown in Table
 - 3) Discharge Duration : Shown in Table
 - 4) Temperature Range : $[-30^{\circ}\text{C}$ to $+60^{\circ}\text{C}$
Please limit storage and/or usage at more than 45°C to less than 2 weeks.
 - 5) Leakage :
Battery does not show leakage after 30 days storage at $50 \pm 2^{\circ}\text{C}$, $90 \pm 5\% \text{R.H.}$
This is checked with the naked eyes.
8. Appearance :
Any dirt, scratch or deformation which cause any trouble at usage, does not show on the battery.
9. Notes : Handling care is specified in I. E. C. Pub. 86-1-9.

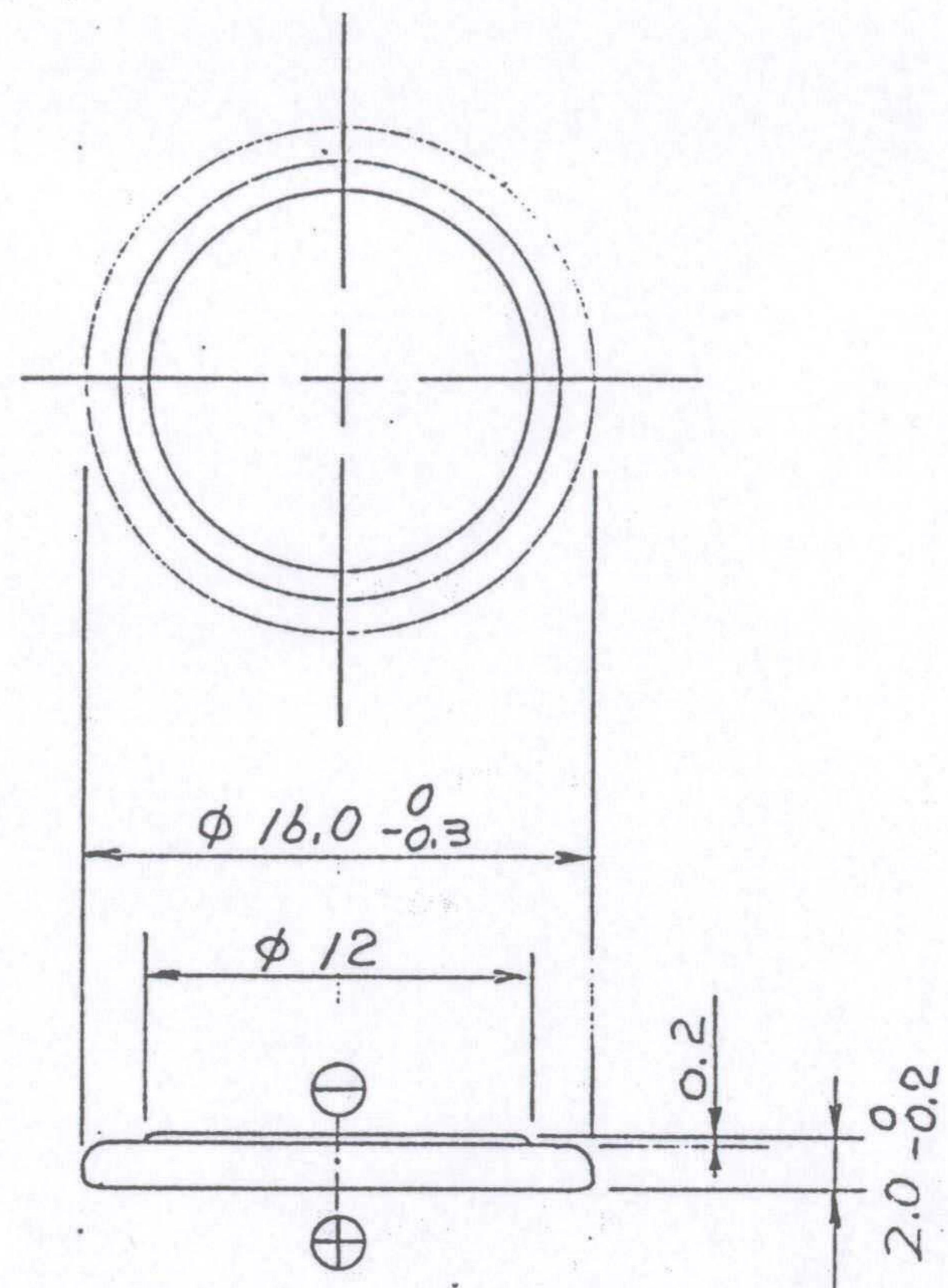

* The dimensions without tolerance have only reference value.

	ITEM	Initial	After 1 Year	After 3 Years
1)	Off-Load Voltage (Min. V.)	3.1 V	3.1 V	3.1 V
2)	Internal Resistance of the fresh battery 1kHz 10mA (Max. Ω.)	50 Ω		
3)	Average Hours Service at 20 °C Load : 30kΩ (End Point 2.5 V.)	790 h	774 h	742 h

3		
2		
1	Mar. 1, 1995	Confirm (Service Hours, Capacity 70→75mA)
Sym.	Date of Revision	Remarks
	Date of stipulation	Stipulated
	Mar. 7, 1988	<div style="display: flex; justify-content: space-between;"> <div style="text-align: center;"> T. Sawo </div> <div style="text-align: center;"> H. Kogure </div> </div>

S P E C I F I C A T I O N

Precautions for Use

Please pay attention to the following points in order to maintain satisfactory operating conditions.

- * Use nickel plated(steel or stainless steel) for power terminal contacts.
- * To ensure stable contact, the contact pressure for power terminals must be at least 50 grams.
- * When measuring battery voltage, use a meter with an internal resistance of 1 MΩ or greater. Correct voltage measurements cannot be obtained otherwise.
- * Batteries are extremely sensitive to the adverse effects of humidity. Be sure to store them in a place which is dry and subject to little temperature change.
- * Do not place near the boiler or radiator, nor expose to the direct sunlight.
- * If button-type batteries are kept in contact with each other, the (+) and (-) terminals may short-circuit, greatly shortening their serviceable life.
- * Button-type batteries may expand slightly during use. Therefore, sufficient space must be provided for this expansion when designing equipment.
- * Before inserting batteries, check to confirm that the terminal contact surfaces on both the equipment and the batteries are clean and that they are not deformed. If the contact surfaces are dirty, clean and dry them thoroughly before inserting batteries.
- * Batteries of the same size and shape may differ in type and grade. When exchanging batteries, confirm that they are the correct type by checking the identification symbol (designated by I.E.C. standards) provided on the battery.
- * Alkaline primary batteries continue to register high voltage even toward the end of their serviceable life. As such, they may be mistakenly judged as yet being strong. If one of several batteries being used in a set is found to be exhausted, it can be assumed that there is very little life remaining in the others even though they may continue to register high voltage.
It is therefore advisable to exchange all of the batteries at the same time.
- * The direction of polarity in a battery may reverse as it nears the end of its serviceable life. This occurs when it is the first among several batteries being used in a set to be exhausted. It is not due to an abnormality in the battery itself.
- * When a lithium battery is short-circuited, even slightly, a certain amount of time is required for its voltage output to recover completely. If the electrical characteristics of the battery are measured before a sufficient amount of time has passed, the battery may appear to be malfunctioning when actually it is merely in a state of recovery.

The batteries should be used correctly, otherwise the set may be damaged due to leakage trouble. Therefore, keep the following precautions in mind.

- * Do not charge, short-circuit, disassemble, heat or dispose the batteries in fire.
- * Insert the batteries in correct polarity position.
- * Do not directly solder to batteries.
- * Do not use spent batteries with new ones.

Small-sized batteries can easily be swallowed.
They must be kept out of the reach of small children.
Also, in the design of battery powered equipment, care should be taken to ensure that batteries cannot be easily removed by children.

3		
2		
1		
Sym.	Date of Revision	Remarks
Date of stipulation	Stipulated	Described
May . 4. 1984		<i>H. Hattori</i>

MATSUSHITA BATTERY INDUSTRIAL CO., LTD.

1 MATSUSHITA-CHO. MORIGUCHI-SHI, OSAKA. JAPAN

(019-019)

Battery Safety Practices

Avoid danger when handling batteries

Lithium batteries contain volatile materials such as lithium, organic solvents and other chemical ingredients. Incorrect handling of lithium batteries may result in heat generation, fire or explosion, with the risk of personal injury or damage. To prevent accidents when handling batteries, be sure to observe the following precautions.

1. Do not stack or jumble batteries

Avoid contact between positive (+) and negative (-) battery poles, and contact with other metal surfaces, as this can cause short circuits with intense current flows and heat.

Stacking or jumbling batteries, as shown at right, may cause short circuits, heat generation, fire or explosion.

Example of stacked and jumbled batteries



* Contact between battery poles may form a discharge circuit and lead to heat generation, fire or explosion.

2. Do not dispose of batteries in fire

Disposal of batteries in fire is extremely dangerous with a risk of explosion and violent flaring.

3. Do not heat batteries

When lithium batteries are heated above 100°C (212°F), the resin used in seals, separators and other parts may be damaged, causing electrolyte leaks and internal short circuits which may lead to fire or explosion.

Enlargement

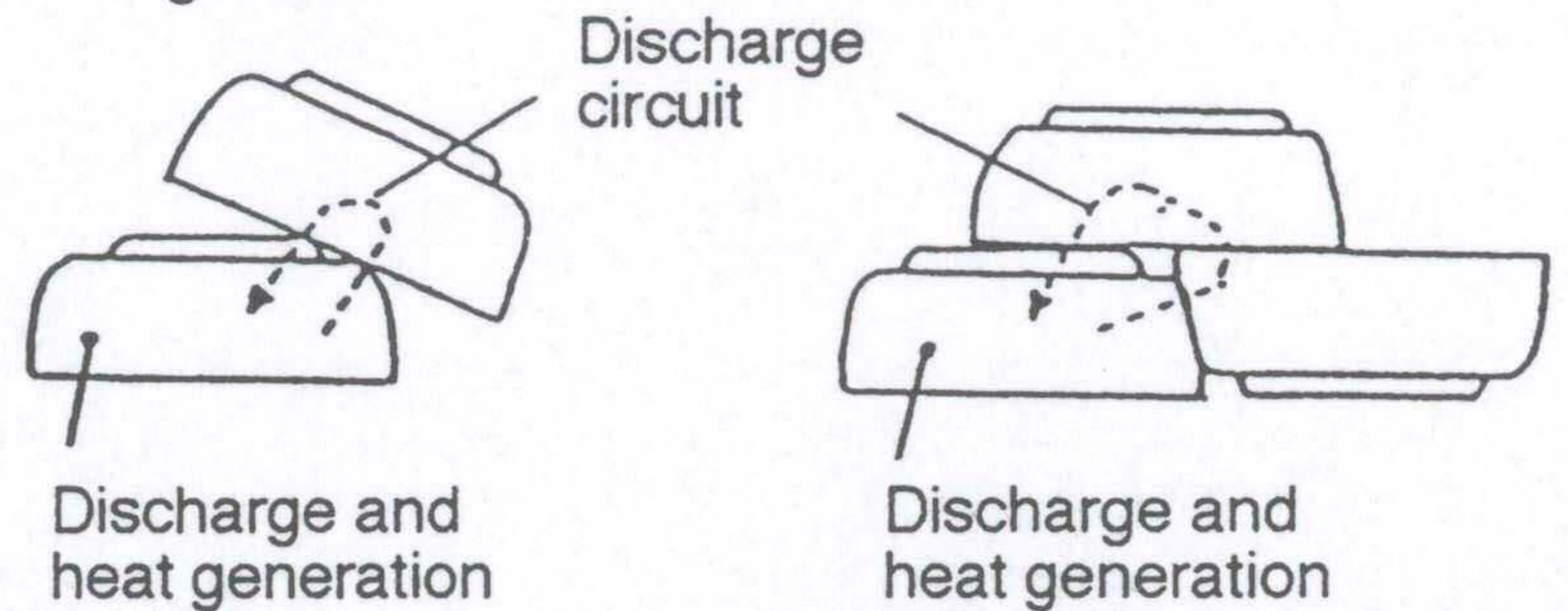

4. Do not solder directly onto batteries

Heat from soldering may damage seals, separators and other parts, causing electrolyte leaks and internal short circuits which may lead to fire or explosion.

5. Do not recharge batteries

Attempting to recharge batteries may result in internal generation of gases, which may lead to swelling, fire or explosion.

6. Do not disassemble batteries

Do not disassemble lithium batteries as this can generate a gas that may irritate the throat. Lithium may also react with moisture to generate heat and fire.

7. Do not deform batteries

When extreme pressure is applied to batteries, seals may be deformed or damaged, causing electrolyte leaks or internal short circuits. This may lead to the risk of heat generation, fire or explosion.

8. Do not mix different types of batteries

For some applications, mixing different types of batteries, or new and old batteries, can cause overdischarge due to differences in voltage and electrical capacities. This may lead to the risk of swelling or explosion.

9. Insert batteries correctly

Depending on the application device, incorrect insertion of batteries, with positive (+) and negative (-) poles reversed, may result in short circuits and the risk of heat generation, fire or explosion.

Please ensure the above precautions are strictly observed by related divisions including production departments, sales departments and external subcontractors. For additional details and information, please contact our sales representatives.

Preventing Accidental Memory Erasure

Coin-type Lithium batteries are widely used for memory backup purposes. However, there have been an increasing number of cases of accidental memory erasure due to inadequate battery contact.

To prevent unexpected memory erasure, consider the following tips for proper use.

<Long-term Continuous Battery Use>

- Use a battery with solderable tab terminals, so that the battery can be permanently soldered to terminal pads on the circuit board (Fig. 1).
 - If the battery requires periodic replacement, use a battery holder (Fig. 2) or a battery with in-line lead connectors (Fig. 3).
- The battery holder can be adjusted to suit any Matsushita lithium battery (Fig. 2).

<Batteries Requiring Short-Term Periodic Replacement --- Using batteries without solderable tab terminals or lead connectors>

- Use gold- or nickel-plated steel or stainless-steel strips for battery terminal contacts. Terminals made of gold-plated phosphor bronze will ensure contact with long-term stability.
 - Y-shaped terminals (double contacts) for both the anode and cathode offer very stable contact (Fig. 4).
- Each contact on the Y-shaped terminals requires a minimum contact pressure of 0.5 N (approximately 50 gf) (Fig. 5).
- To guard against momentary contact failures of a few milliseconds in duration, use the tantalum capacitor-diode-resistor circuit shown in Fig. 6.
- * Do not touch the contact surfaces of the battery with bare hands, as this will increase the contact resistance and impair proper contact.

Figures 1 through 6 show examples of how to ensure proper battery contact.

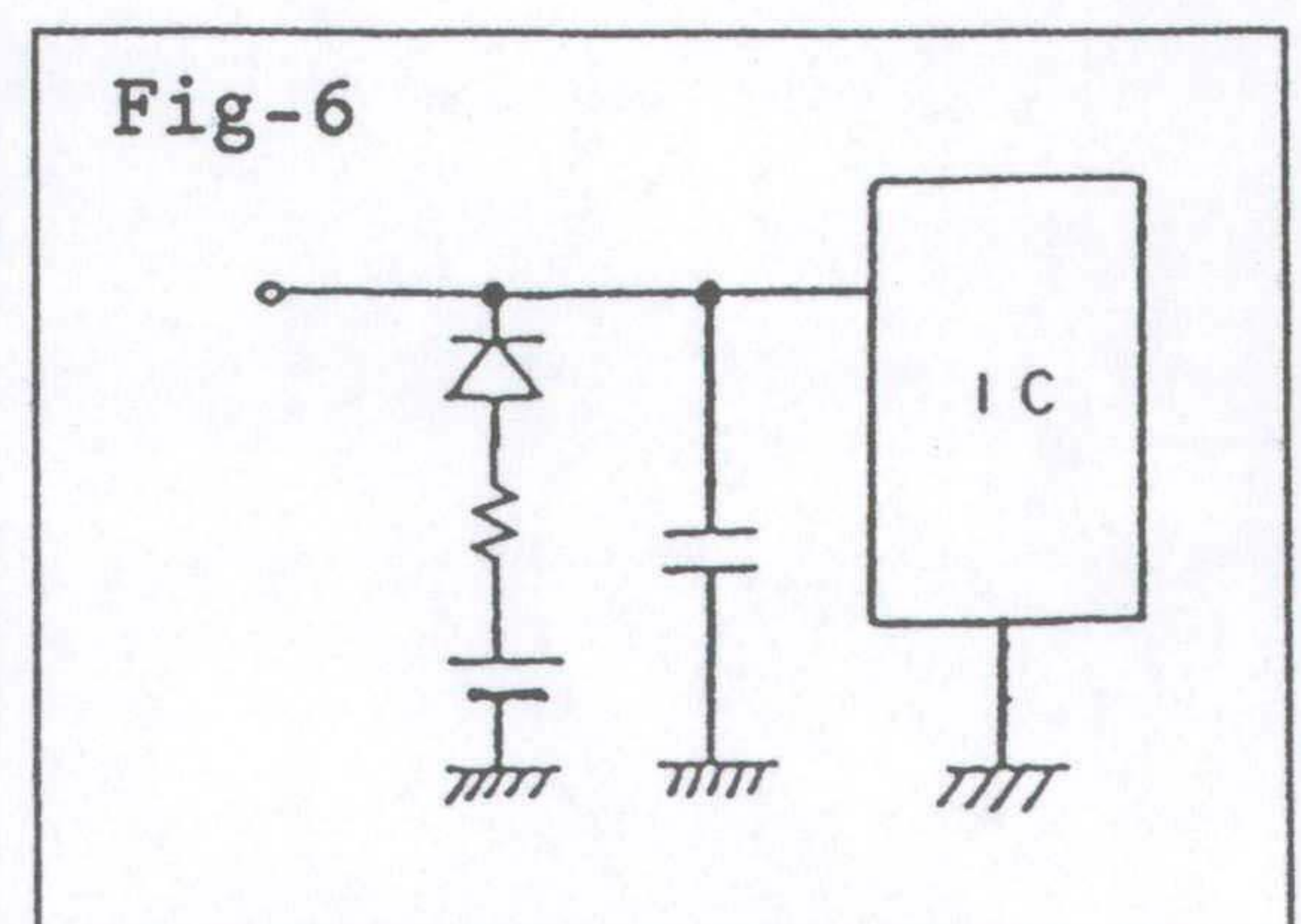
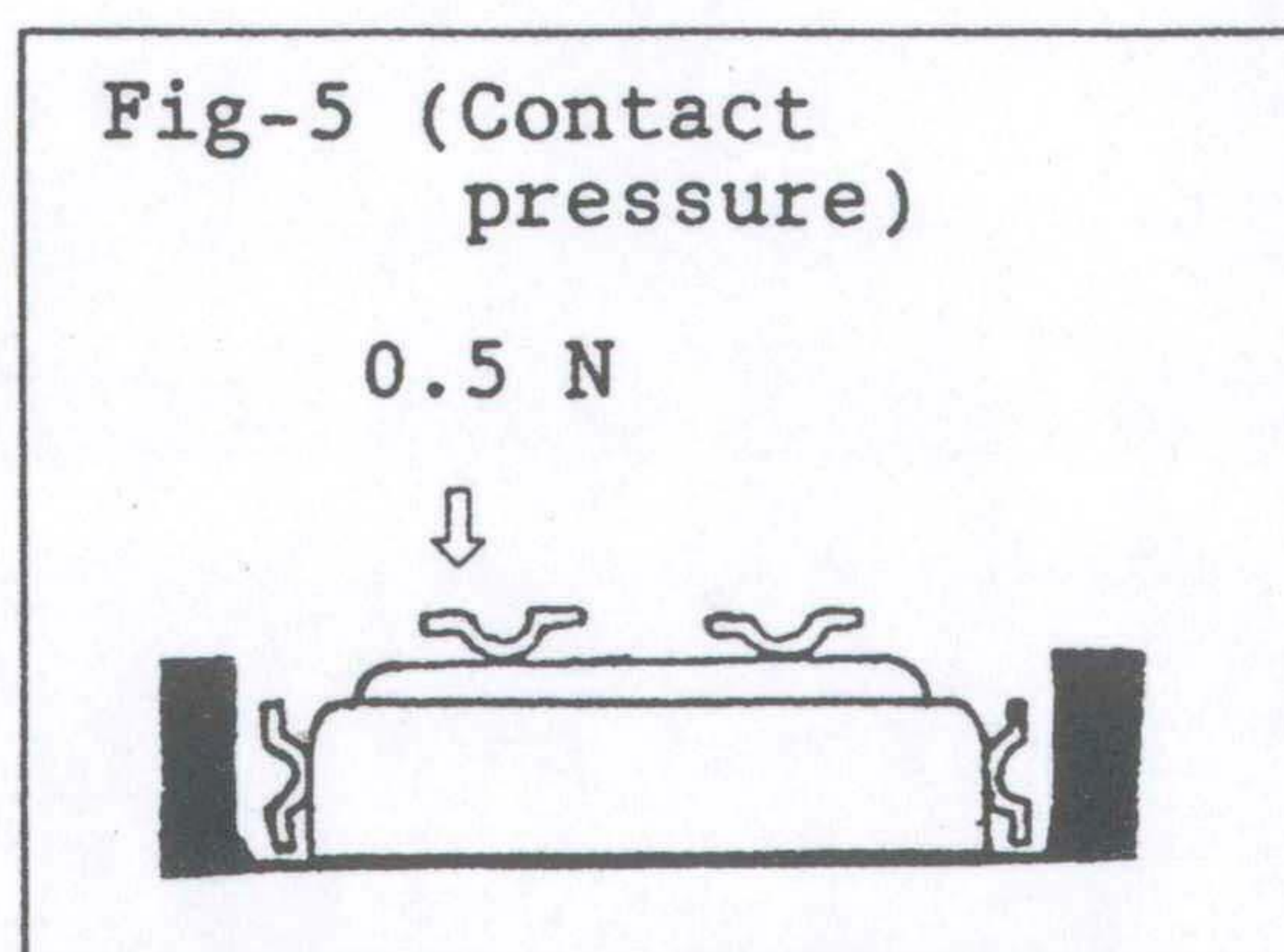
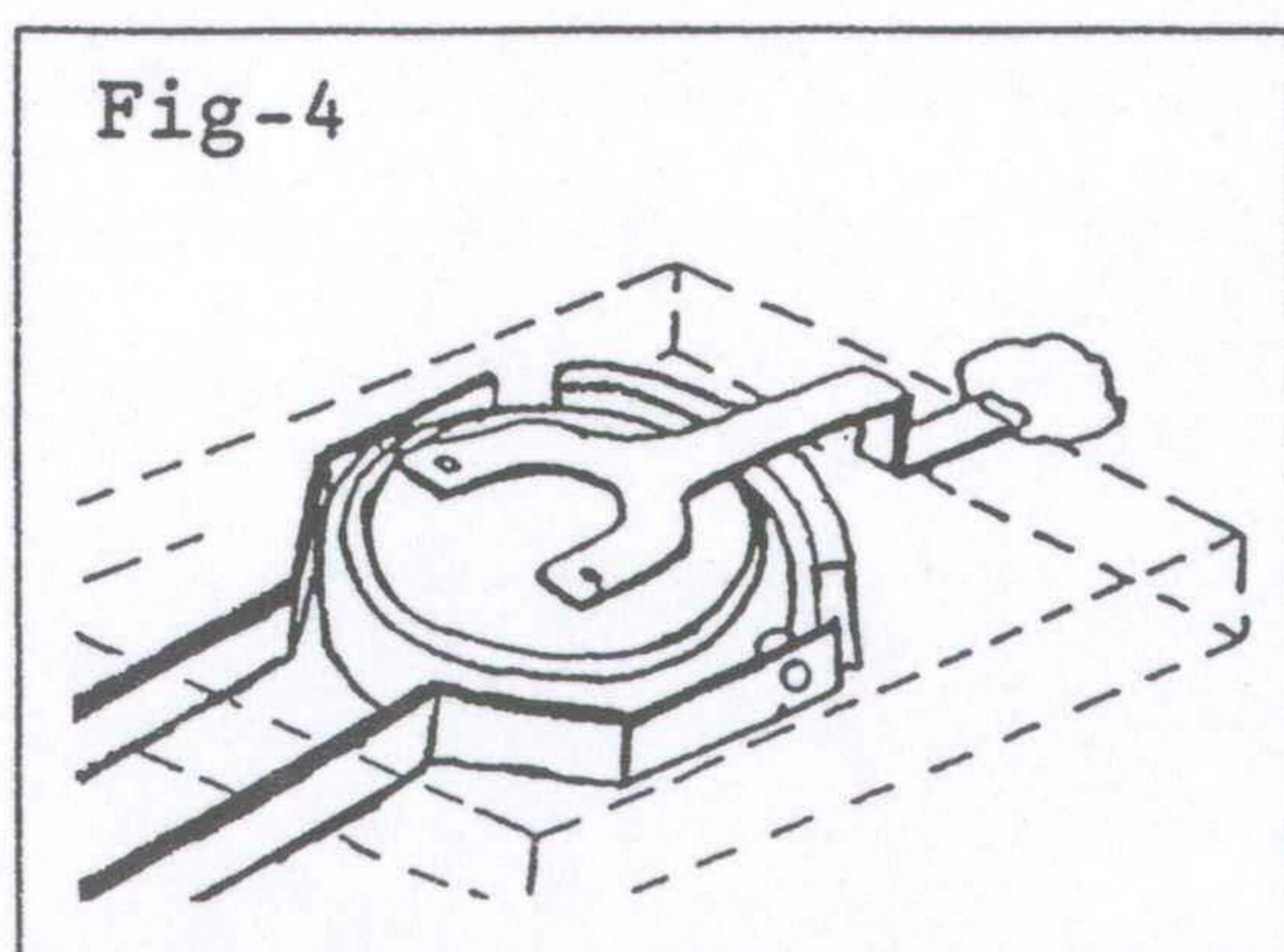
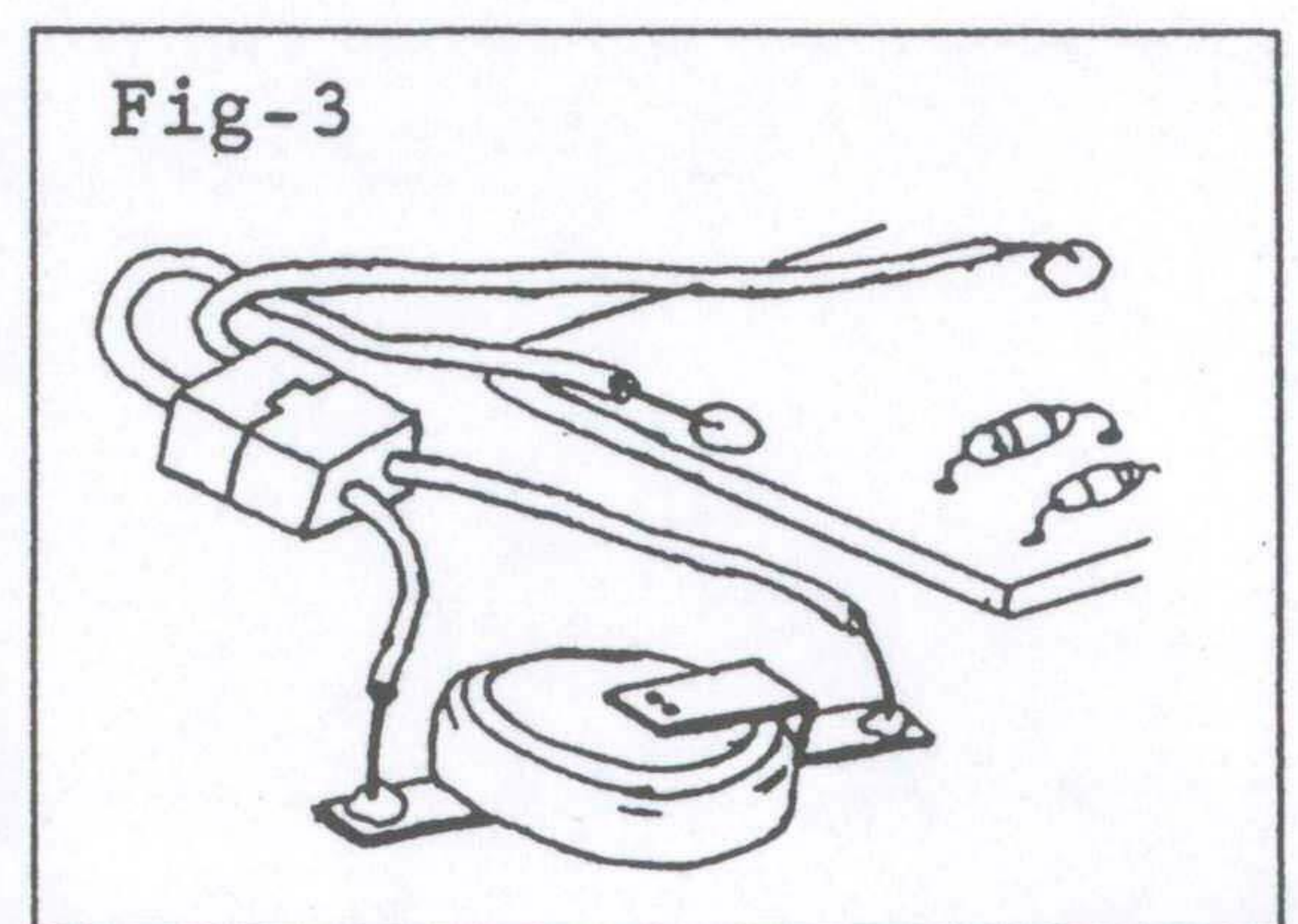
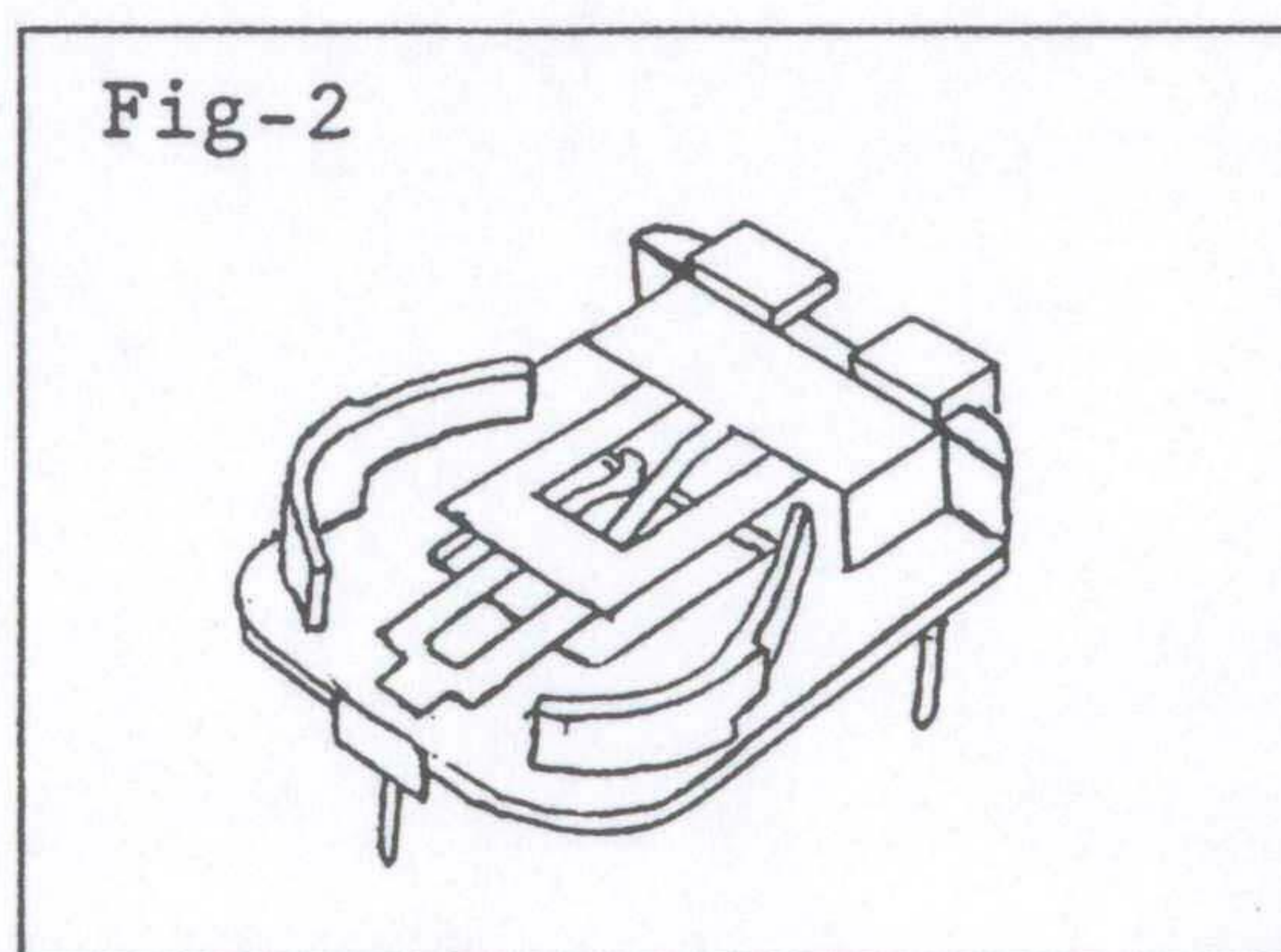
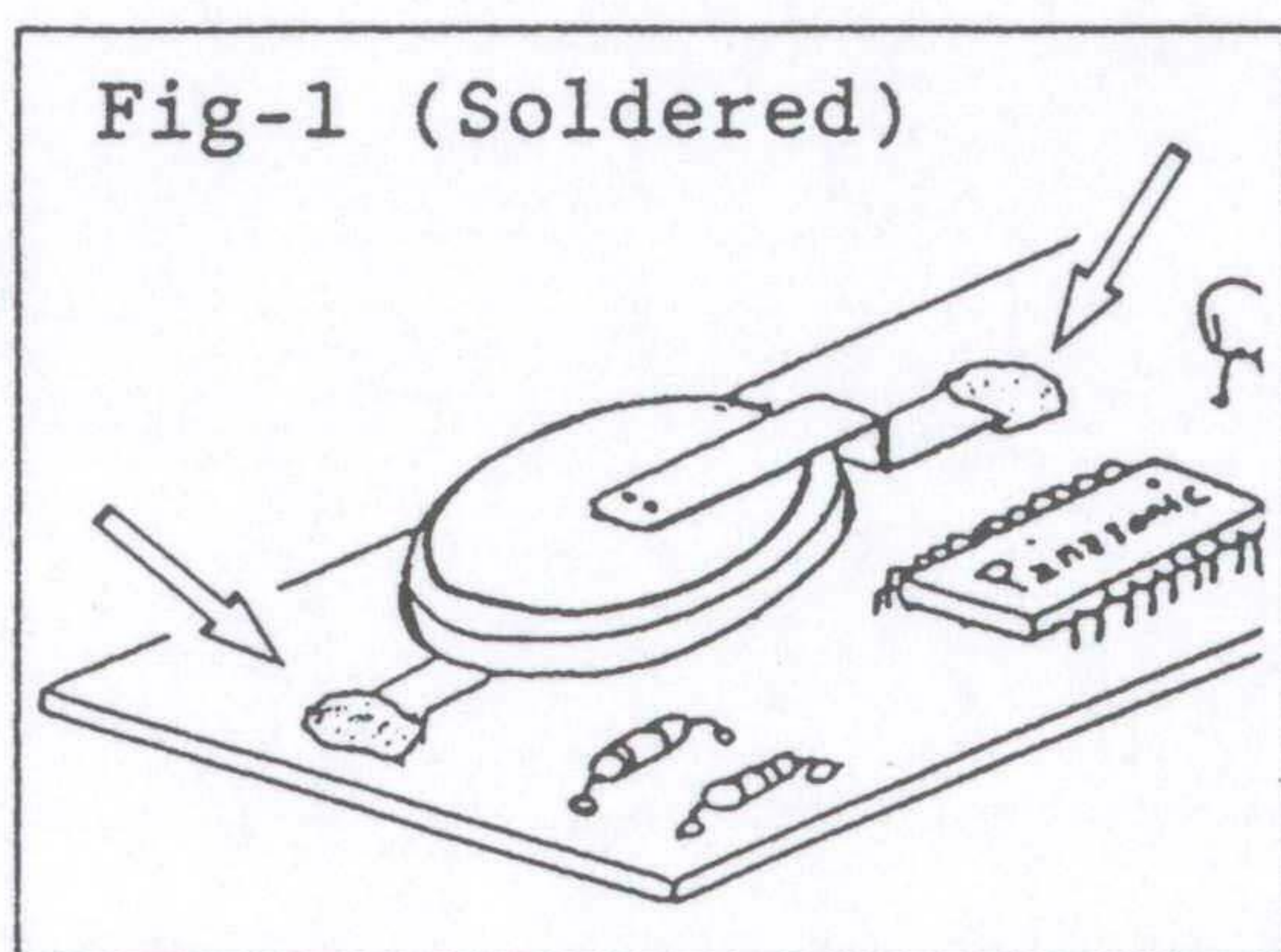

For more information, please make contact with your local dealer.

Beware of Antistatic Conductive Materials

Whenever terminal-mounted backup batteries or coin-type lithium batteries contact conductive materials, they discharge. Measures to protect semiconductor parts from static damage have been implemented in plants that use such ICs and LSIs. A number of protective materials are presently being used, and all contain blends of carbon, aluminum and other metals that make them conduct.

Antistatic conductive materials include packing bags, trays, mats, sheets, film and resin cases. Sheets, for example, have a resistance of 10^3 to $10^6 \Omega$, which means that when they contact the positive and negative terminals of a battery, they will discharge the battery.

In a lithium battery, a current flow of several μA to several mA reduces its voltage and electrical capacity. We recommend constant attention when using batteries around protective materials.

Examples

A terminal-mounted battery with its terminals inserted into a conductive mat is completely discharged after several days.

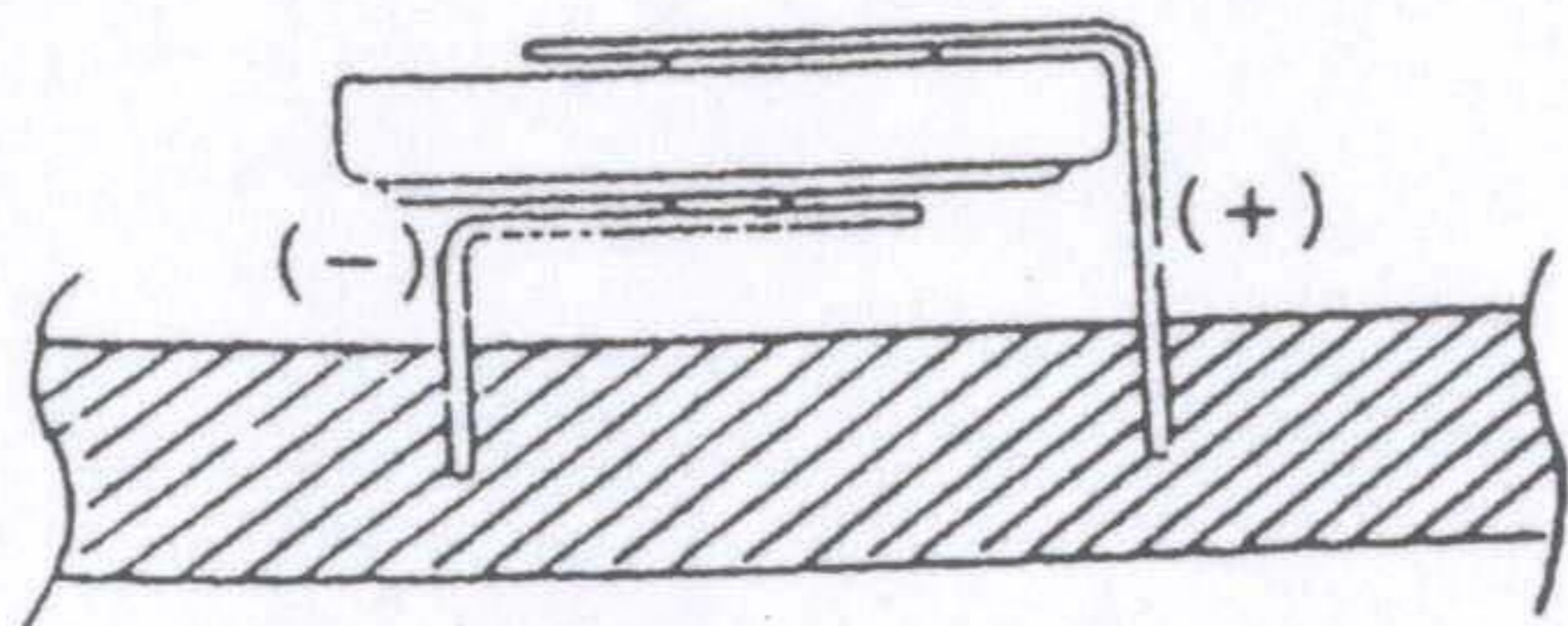

Conductive mat

A PCB-mounted battery is completely discharged by contact with the conductive resin case.

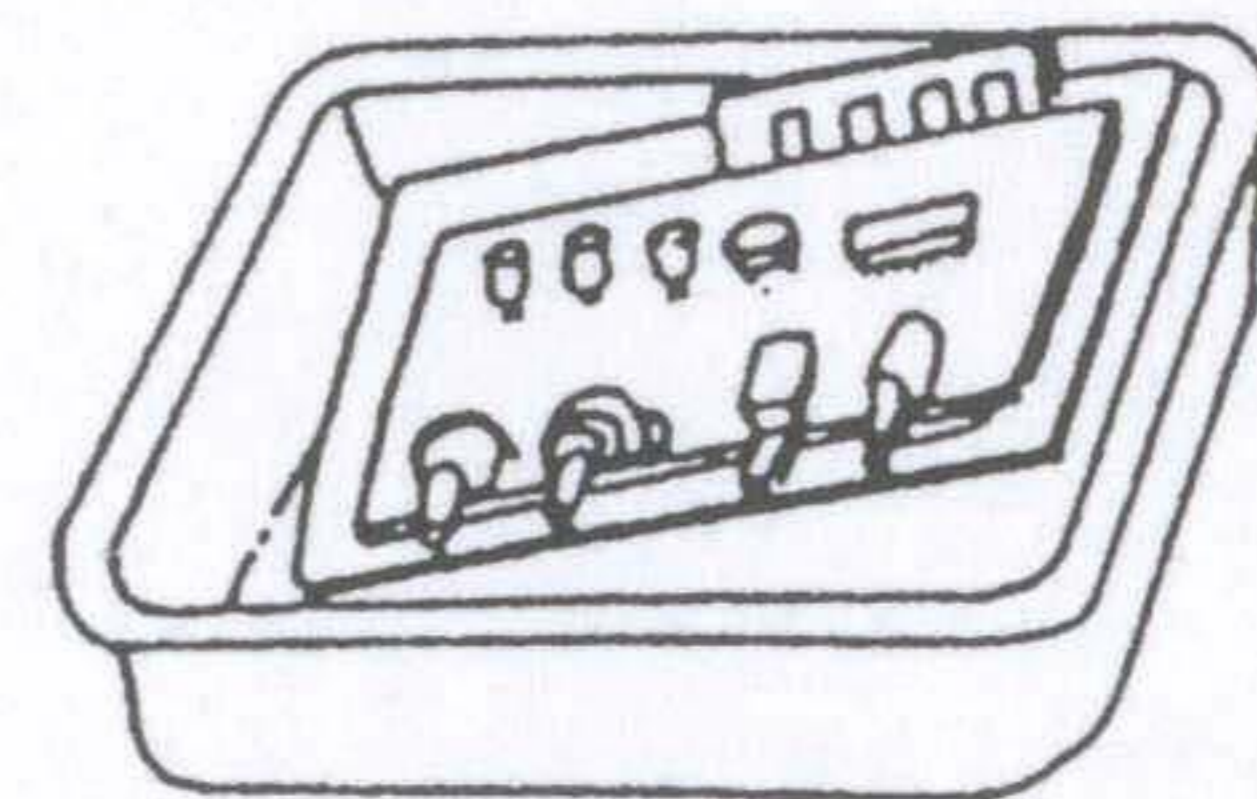

Conductive resin case

PCB-mounted batteries are discharged by contact with spacers and conductive rubber sheets.

Spacer

Conductive rubber sheet

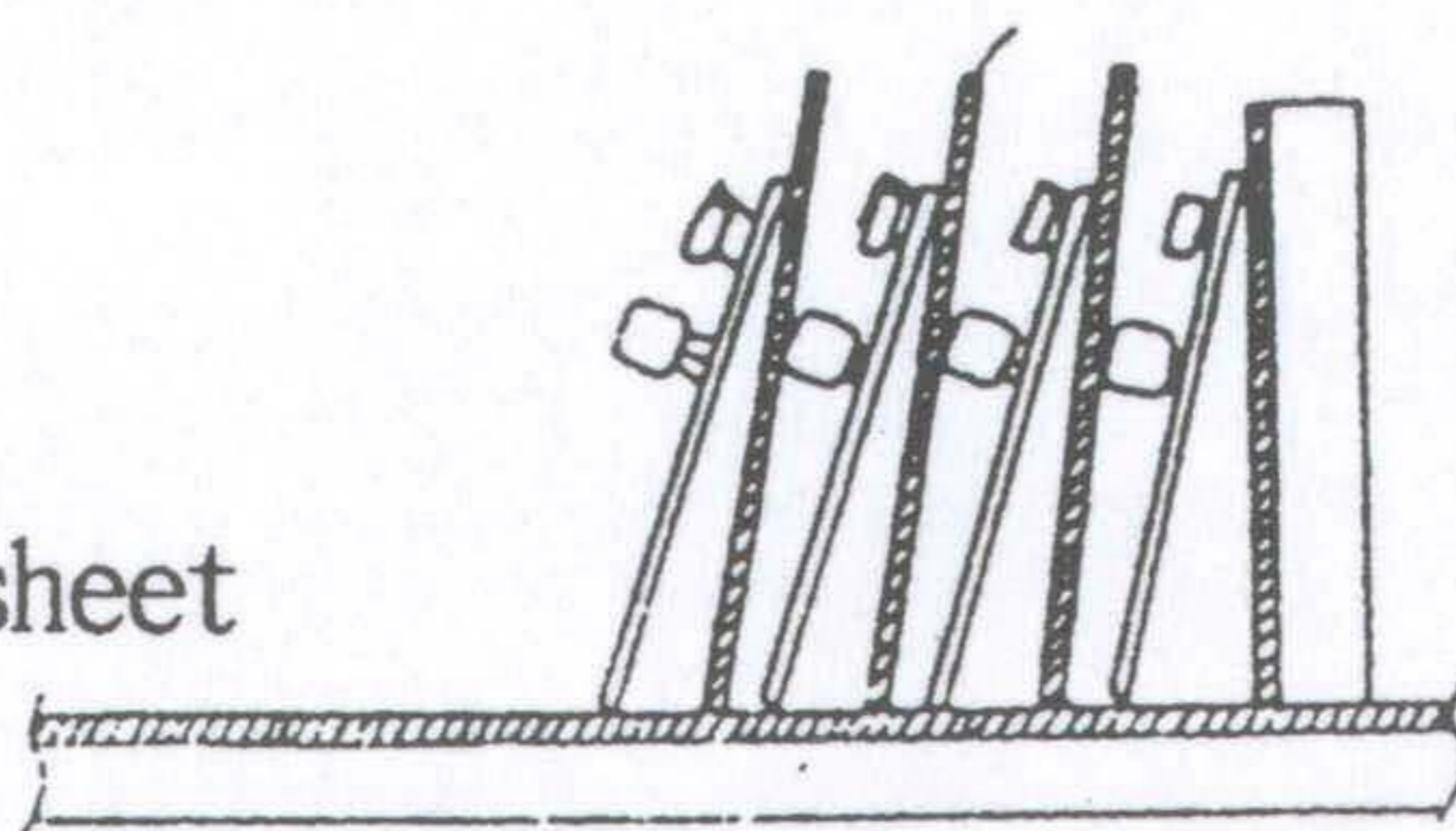

Batteries left on a work bench with positive and negative terminals in direct contact with the grounded rubber sheet cover are completely discharged.

Ground wire

Conductive sheet

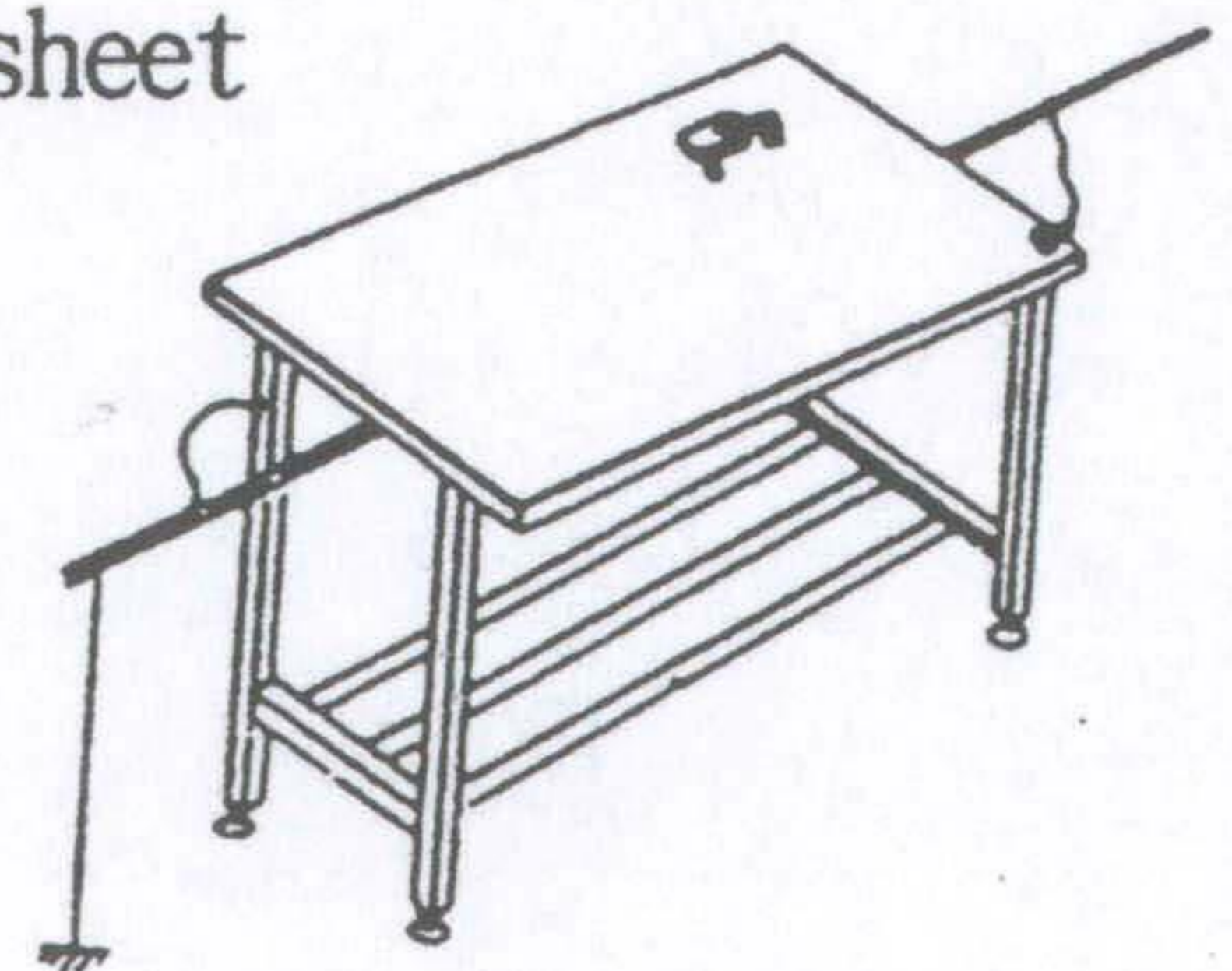

For more information, please make contact with your local dealer.